

(No Model.)

3 Sheets—Sheet 1.

D. O. SMITH.

APPARATUS FOR BORING LOCOMOTIVE CYLINDERS.

No. 599,265.

Patented Feb. 15, 1898.

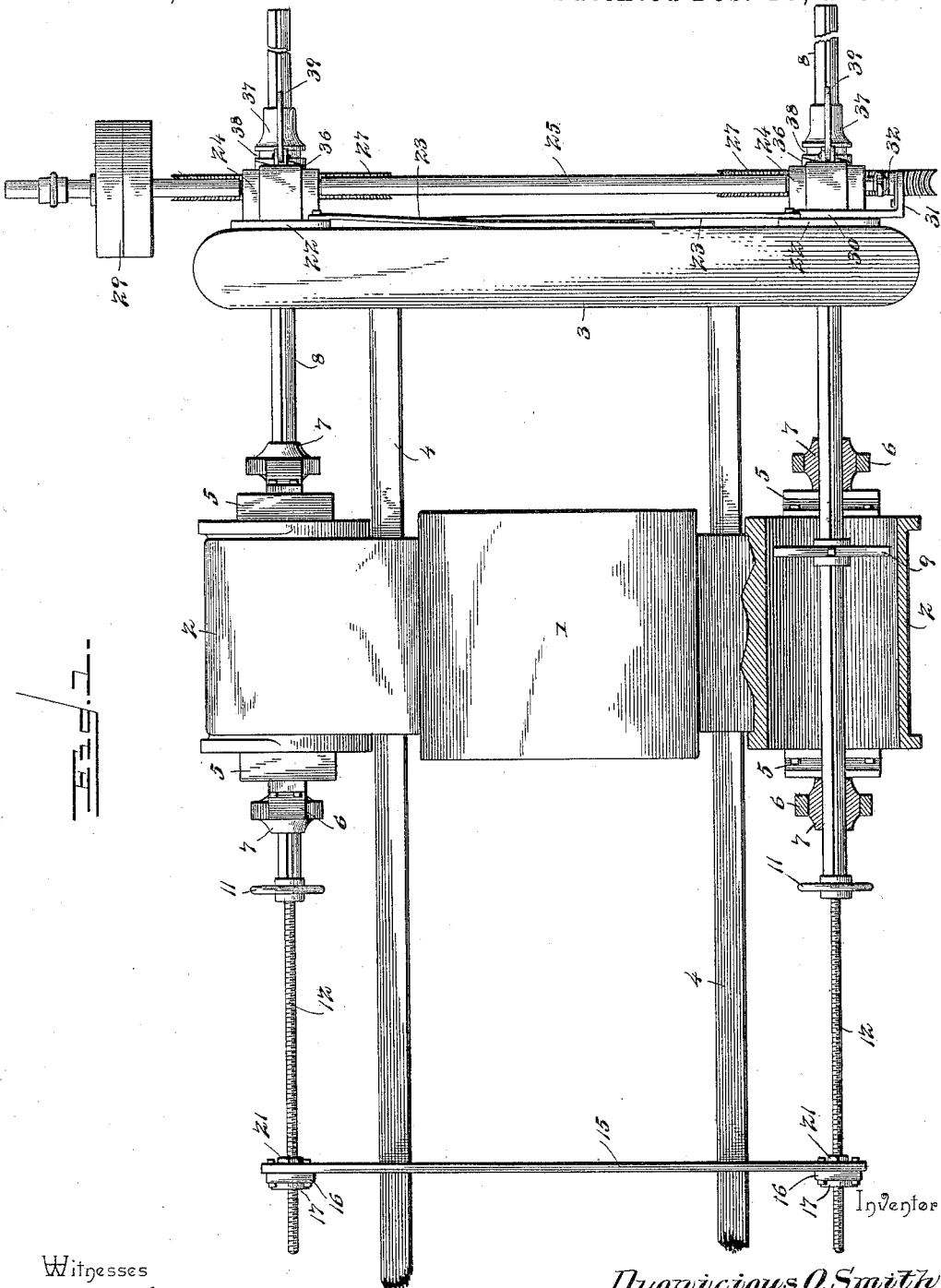

Witnesses
E. Stewart
V. B. Hillyard

By *W. S.* Attorneys,

Dionicious O. Smith

C. A. Snow & Co.

(No Model.)

3 Sheets—Sheet 2.

D. O. SMITH.

APPARATUS FOR BORING LOCOMOTIVE CYLINDERS.

No. 599,265.

Patented Feb. 15, 1898.

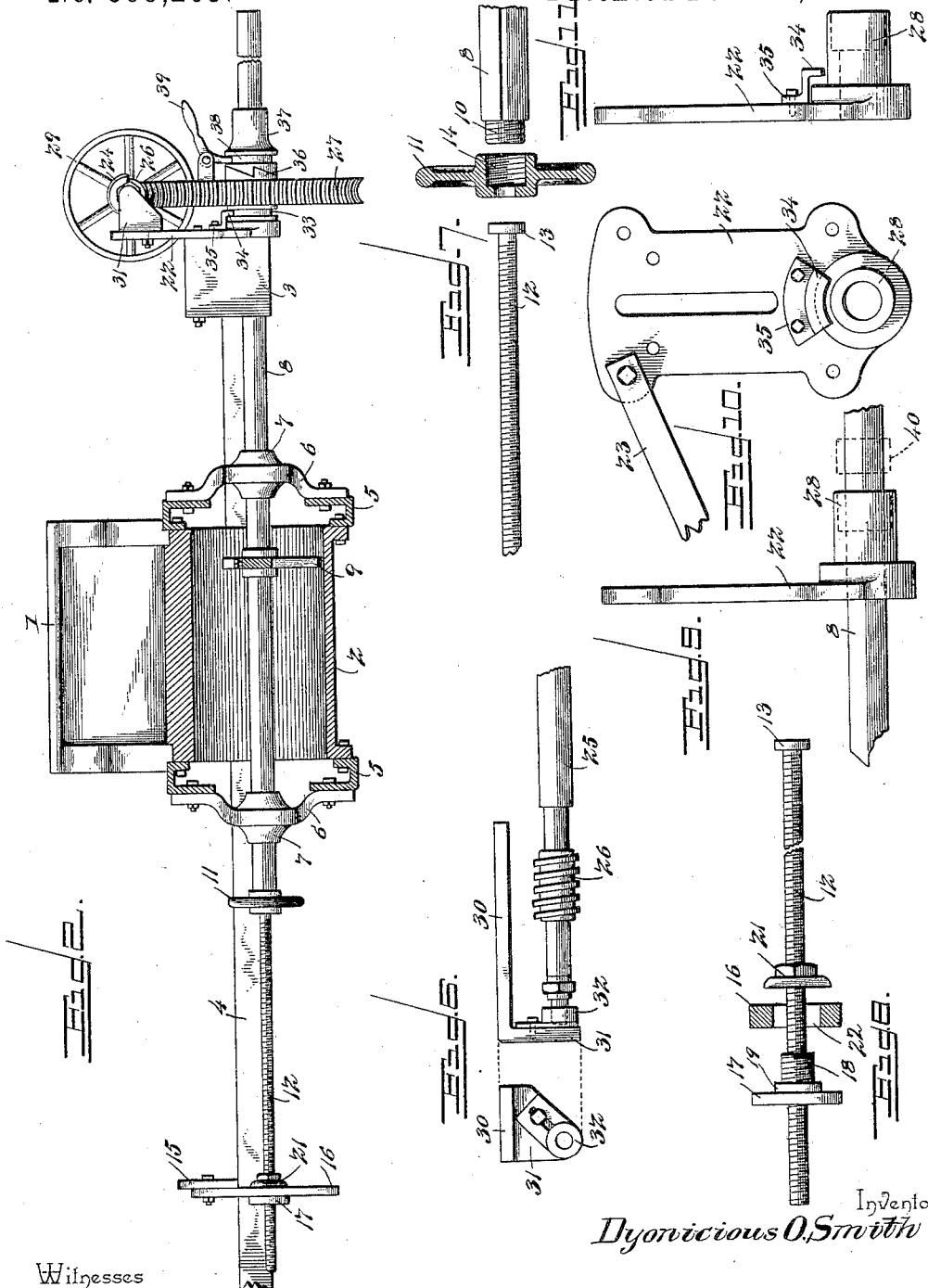

Witnesses
E. H. Stewart
V. B. Hillyard

By *W. O. S.* Attorneys.

Inventor
Dionisius O. Smith

C. A. Snow & Co.

(No Model.)

3 Sheets—Sheet 3.

D. O. SMITH.

APPARATUS FOR BORING LOCOMOTIVE CYLINDERS.

No. 599,265.

Patented Feb. 15, 1898.

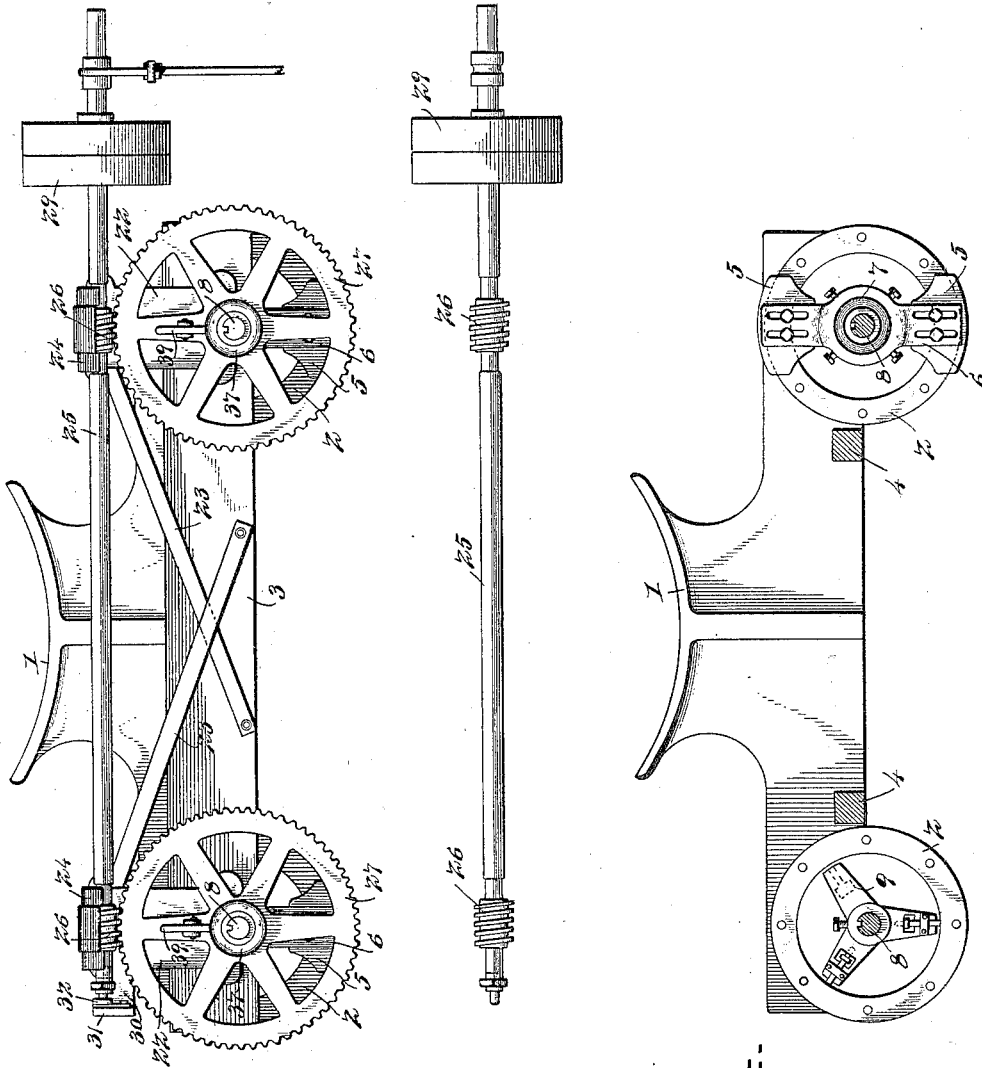

E. S. S.

E. S. S.

E. S. S.

Witnesses
E. C. Stewart
V. B. Hillyard

By *Boyer* Attorneys,

Inventor
Dionicious O. Smith

C. A. Snow & Co.

UNITED STATES PATENT OFFICE.

DYONICIOUS OLIVER SMITH, OF WHISTLER, ALABAMA.

APPARATUS FOR BORING LOCOMOTIVE-CYLINDERS.

SPECIFICATION forming part of Letters Patent No. 599,265, dated February 15, 1898.

Application filed October 5, 1897. Serial No. 654,131. (No model.)

To all whom it may concern:

Be it known that I, DYONICIOUS OLIVER SMITH, a citizen of the United States, residing at Whistler, in the county of Mobile and State of Alabama, have invented a new and useful Apparatus for Boring Locomotive-Cylinders, of which the following is a specification.

This invention has for its object to provide a mechanism for simultaneously boring the cylinders of a locomotive when in position, thereby enabling the work to be performed in about the same time generally required for boring each cylinder separately. The apparatus is constructed with a view of being fitted to the frame of the engine and is adjustable so as to be applied to different-sized engines within certain limits. Each boring-bar has an independent feed mechanism and is operated individually from a common shaft, clutches being interposed to admit of either boring-bar being thrown out of gear, as desired.

For a full understanding of the merits and advantages of the invention reference is to be had to the accompanying drawings and the following description.

The improvement is susceptible of various changes in the form, proportion, and the minor details of construction without departing from the principle or sacrificing any of the advantages thereof, and to a full disclosure of the invention an adaptation thereof is shown in the accompanying drawings, in which—

Figure 1 is a top plan view showing the boring mechanism in position, one of the cylinders and the guides for the boring-bar thereof being in section. Fig. 2 is a side elevation, the rear cylinder being in section. Fig. 3 is an end view. Fig. 4 is a detail view of the saddle and cylinders, showing the relation of the boring-bars and the mountings therefor. Fig. 5 is a detail view of the power-driven shaft for operating the boring-bars by means of intermediate gearing. Fig. 6 is a detail view of the thrust-brace for the power-driven shaft. Fig. 7 is a detail view of a boring-bar, the feed-screw therefor, and the feed-wheel for connecting them. Fig. 8 is a detail view of the feed-screw, the feed-nut, and the guide-yoke to which the feed-nuts are clamped. Fig. 9 is a detail view in elevation of a journal-bearing brace. Fig. 10 is a front view of the part illustrated in Fig. 9. Fig. 11

is an edge view of the journal-bearing brace, showing the guide-clamp in position.

Corresponding and like parts are referred to in the following description and indicated in the several views of the accompanying drawings by the same reference characters.

So much of the engine-frame is illustrated as is necessary to show the parts in operative relation, the saddle 1, cylinders 2, pilot-sill 3, and longitudinal bars 4 being well-known parts of the frame of a locomotive, to which the working parts are fitted in the manner presently to be described. The ends of the cylinders are similarly equipped, having plates 5 bolted thereto, to which yokes 6 are adjustably connected. Journals 7 are secured centrally of the yokes 6 and form bearings for the boring-bars 8, which are supplied with boring-tools 9 of ordinary construction. The rear ends of the boring-bars 8 are reduced and threaded, as shown at 10, and receive the feed-wheels 11, mounted upon the feed-screws 12 and screwed upon the threaded ends 10 of the boring-bars.

The feed-screws 12 have heads 13 at their inner ends, which are clamped between the threaded ends 10 and the inner or shouldered end of the threaded opening 14, formed in the hub of each feed-wheel. When it is required to independently adjust the boring-bars, the one or the other or both feed-wheels are loosened and the feed-screws 12 are turned by a lathe-dog or other means, thereby advancing or withdrawing the boring-bars, as required, after which the wheel-nuts are retightened. Another way for attaining the same result is to throw the boring-bars out of gear by means of the levers 39 and turning the feed-wheels without releasing the feed-screws from the boring-bars.

A yoke 15 is located in the rear of the cylinders and has guide-plates 16 bolted thereto at its ends, to which are clamped the feed-nuts 17, by means of which the feed-screws are moved longitudinally when turned. Each feed-nut 17 has a threaded portion 18 and a raised portion 19, the latter entering an opening 20 in the plate 16 and the threaded portion 18 receiving a clamp-nut 21, by means of which the feed-nut is secured to the plate 16.

Journal-bearing braces or brackets 22 are secured to the ends of the pilot-sill 3 and are

strengthened at their upper ends by braces or stays 23, interposed between them and the pilot-sill. Journal-bearings 24 are provided at the upper ends of the brackets 22 to receive the power-driven shaft 25, which is formed with or has applied thereto worm-pinions 26, which intermesh with worm-gears 27, mounted upon bearings 28, projecting from the brackets 22. This shaft 25 is provided at one end with pulleys 29, the one being tight and the other loose, and to which the driving-belt (not shown) is applied for rotating the shaft 25 when the boring mechanism is in operation. The end thrust of the shaft 25 is sustained by a thrust-brace 30, secured to the upper end of a bracket 22, and this thrust-brace has its outer end bent, as shown at 31, and a bearing 32 adjustably connected therewith, so as to be brought in line with the shaft and allow for any variation in the fitting of the parts.

The worm-gears 27 are loosely mounted upon the journals 28 and have the inner ends of their hubs formed with annular grooves 33, into which project the bent ends 34 of clamps 35, bolted to the brackets or journal-bearing braces 22. By this means the worm-gears are retained in working position. The outer ends of the worm-gear hubs are formed with half-clutches 36, which are engaged by corresponding half-clutches at the inner ends of clutch-sleeves 37, slidingly mounted upon the boring-bars and caused to rotate therewith by a feather-and-spline connection or other means commonly resorted to for imparting a rotary motion to relatively-sliding parts. These clutch-sleeves 37 are formed with annular grooves 38, which receive the inner ends of shipper-levers 39, fulcrumed to the worm-gears 27, and which provide means for throwing either one or both of the boring-tools out of action, as required.

When it is required to bore the cylinders of a locomotive-engine, the parts are assembled about as shown and herein described, and the boring-bars are rotated by applying power to the shaft 25. The boring-tools are automatically advanced by the turning of the feed-screws clamped to the boring-bars in the manner specified, and should it become necessary to stop one or the other of the boring-tools it is thrown out of action by operating the shipper-lever 39 corresponding therewith, which disconnects the clutch-sleeve from the worm-gear, as will be readily understood. When the boring-bars are in mesh with the shaft 25, the boring-tools are advanced alike to the work, and if from any cause it be required to retard one of the boring-tools or advance it more rapidly than the other the boring-bar carrying such tool is unshipped from the shaft 25 by means of the lever 39 and is operated by means of the hand-wheel 11, connected therewith. During this adjustment the boring-tool does not perform any work, since it is not rotated; but it can be moved rapidly, so as to clear any depression

which may exist in the surface of the cylinder. In this connection it is to be understood that the pitch of the thread of the feed-screws 12 is such as to cause the boring-tools to overlap and make a continuous cut and will depend upon the relative speed at which the boring-bars are rotated.

A bearing-sleeve 40 is inserted in an enlarged opening in the outer end of each bearing 28 and is what is known as a "ball-bearing" and admits of the boring-bars being centrally disposed within the cylinders and obtaining bearings in the parts 28 and 40 without requiring the pilot-sill to be absolutely at right angles to the axes of the cylinders.

Having thus described the invention, what is claimed as new is—

1. In apparatus for boring engine-cylinders, the combination of a boring-bar bearing a boring-tool and having an end portion reduced and threaded, a feed-screw having a head at its inner end, and a feed-wheel having the headed portion of the feed-screw fitted in an opening thereof and having the said opening enlarged and threaded to receive the threaded end of the boring-bar upon which it is screwed to clamp the feed-screw thereto, substantially as set forth.

2. In apparatus for boring engine-cylinders, the combination of a boring-bar provided with a boring-tool, a feed-screw having connection with the boring-bar, a plate having an opening, a feed-nut mounted upon the feed-screw and having an enlarged or raised portion fitted into the opening of the aforesaid plate and formed with a threaded extension, and a clamp-nut mounted upon the threaded extension of the feed-nut to secure the latter to the plate, substantially as set forth.

3. In apparatus for boring the cylinders of a locomotive-engine, the combination of a pair of boring-bars provided with boring-tools, feed-screws having independent connection with the boring-bars, a yoke, plates secured to the ends of the yoke, and feed-nuts mounted upon the feed-screws and secured to the said plates, substantially as set forth.

4. In apparatus for boring engine-cylinders, the combination of a boring-bar provided with a boring-tool, means for feeding the boring-bar, a bearing, a gear-wheel loosely mounted upon the bearing and having power applied thereto, a clutch-sleeve mounted upon the boring-bar and caused to turn therewith by a feather-and-spline connection, and having a half-clutch to engage with a corresponding half-clutch of the aforesaid gear-wheel, and a shipper-bar for throwing the clutch-sleeve into and out of engagement with the gear-wheel, substantially as set forth.

5. In apparatus for boring engine-cylinders of locomotives, the combination of a pair of boring-bars provided with boring-tools, independent feed mechanism applied to the boring-bars, gear-wheels loosely mounted upon bearings, a power-driven shaft in mesh with the said gear-wheels, sleeves mounted upon

the boring-bars and having a feather-and-spline connection therewith, and constructed to have clutched engagement with the aforesaid gear-wheels, and independent means for throwing the clutch-sleeves into and out of engagement with the gear-wheels, substantially as set forth.

6. The herein-described apparatus for boring the cylinders of locomotive-engines, comprising brackets provided with bearings and secured to the pilot-sill, worm-gears loosely mounted upon bearings of the said brackets, guide-clamps secured to the brackets and having portions entering annular grooves in the hub ends of the worm-gears, a power-driven shaft journaled in bearings applied to the said brackets and having worm-pinions intermeshing with the worm-gears, a thrust-brace applied to an end of the power-driven shaft and secured to one of the aforesaid brackets, boring-bars, clutch-sleeves mounted upon the boring-bars to turn therewith, inde-

pendent means for throwing the clutch-sleeves into and out of engagement with the worm-gears, feed-screws, feed-wheels connecting the feed-screws with the boring-bars, a yoke, plates secured to the yoke, and feed-nuts mounted upon the feed-screws and secured to the said plates, substantially as set forth.

7. In apparatus for simultaneously boring engine-cylinders, the combination of boring-bars provided with boring-tools, independent feed mechanism applied to each boring-bar, means for actuating the boring-bars, and a clutch for each boring-bar to throw it into and out of action, substantially as described.

In testimony that I claim the foregoing as my own I have hereto affixed my signature in the presence of two witnesses.

DYONICIOUS OLIVER SMITH.

Witnesses:

J. D. GURGANUS,
BENJ. JOHNSTON.